

UNLESS OTHERWISE SPECIFIED:		NAME	DATE	Designed by Tom Griffin	
DIMENSIONS ARE IN INCHES TOLERANCES: FRACTIONAL $\pm 1/64$ ANGULAR: MACH $\pm 1/2$ Deg. TWO PLACE DECIMAL $\pm .010$ THREE PLACE DECIMAL $\pm .005$		DRAWN	TG	12/25/11	TITLE: MICROMETER CARRIAGE STOP FOR THE ATLAS LATHE
		CHECKED	TG	12/25/11	
DO NOT SCALE DRAWING		SIZE		DWG. NO.	REV
MATERIAL		A			A
FINISH		Quan		SCALE: 3:4	WEIGHT:
				SHEET 1 OF 1	

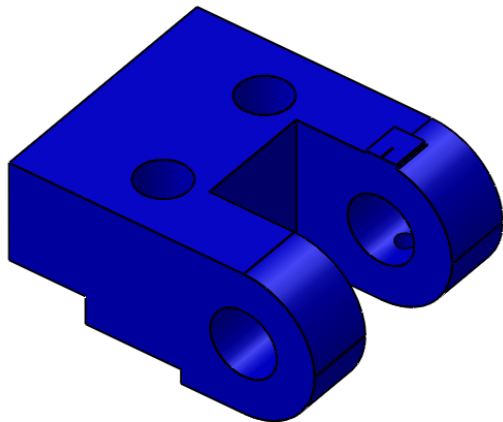

UNLESS OTHERWISE SPECIFIED:		NAME	DATE	Designed by Tom Griffin	
DIMENSIONS ARE IN INCHES TOLERANCES: FRACTIONAL \pm 1/64 ANGULAR: MACH \pm 1/2 Deg. TWO PLACE DECIMAL \pm .010 THREE PLACE DECIMAL \pm .005		DRAWN	TG	12/24/11	TITLE: BODY, MICROMETER CARRIAGE STOP
		CHECKED	TG	12/24/11	
DO NOT SCALE DRAWING				SIZE	REV
MATERIAL		MILD STEEL		A	B
FINISH	NONE	Quan		SCALE: 1:1	WEIGHT:
				SHEET 1 OF 1	

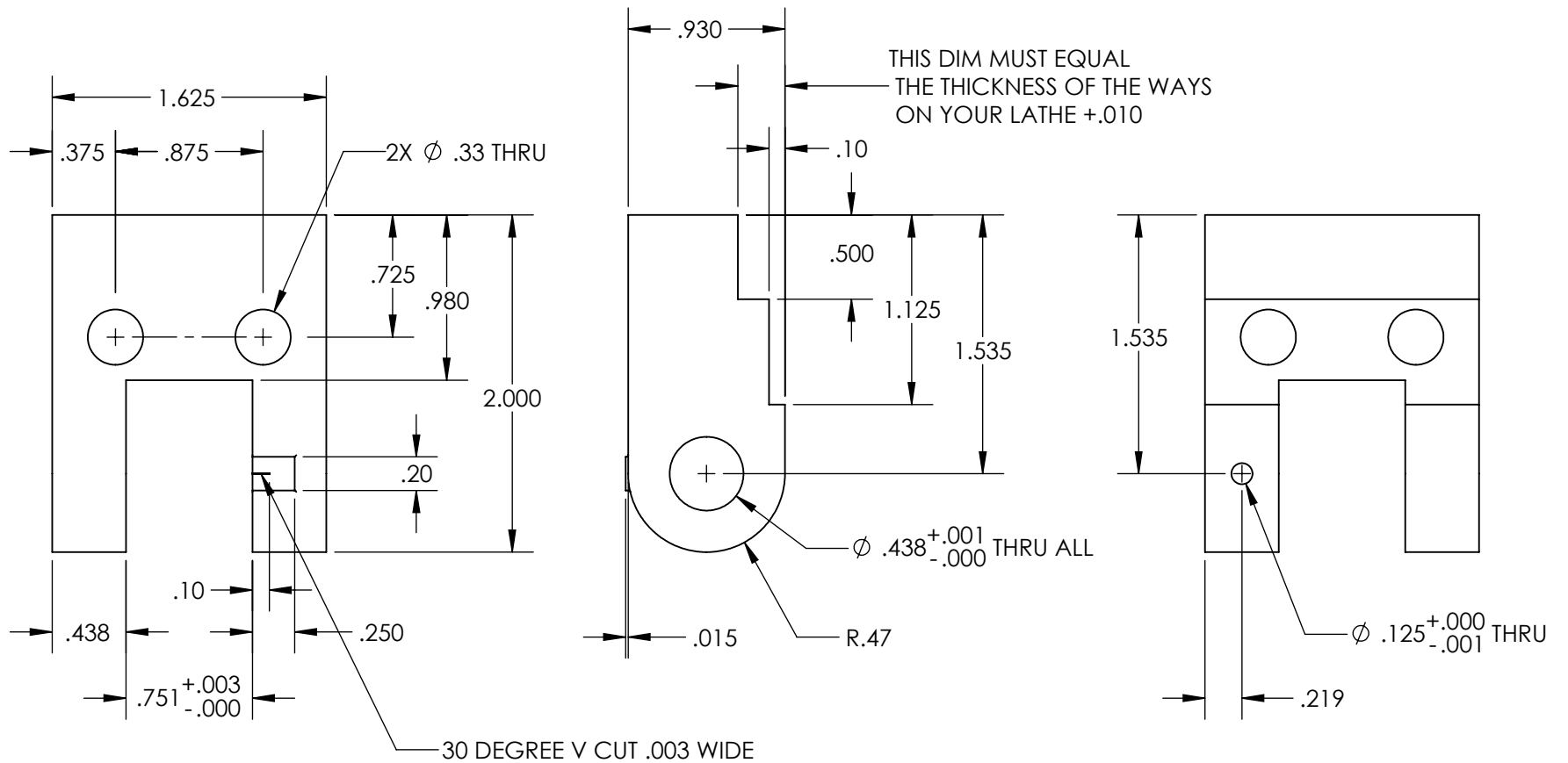
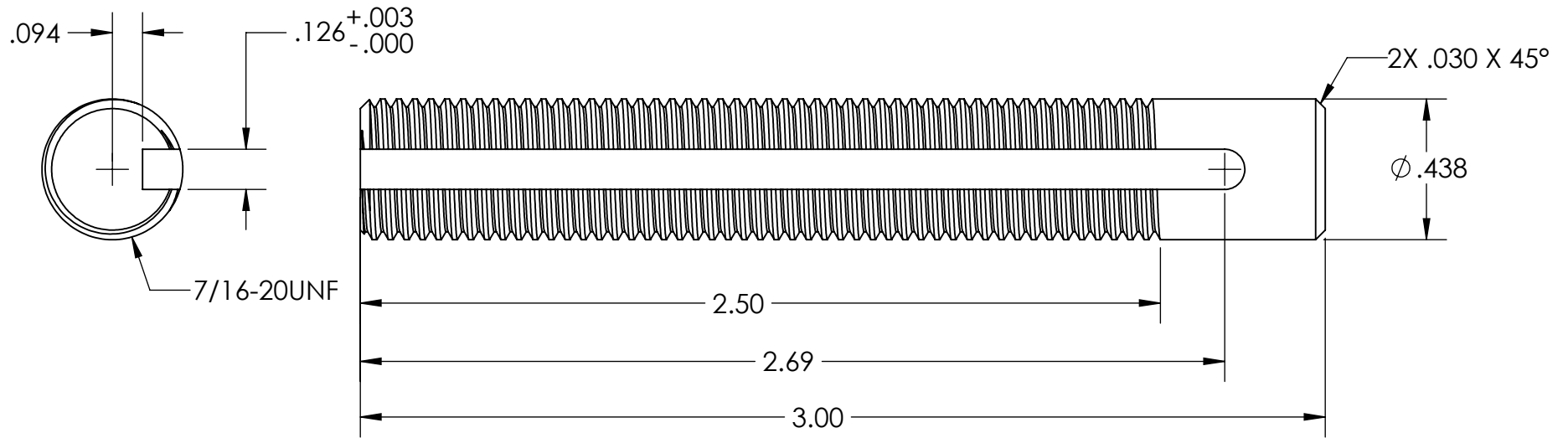

UNLESS OTHERWISE SPECIFIED:		NAME	DATE	Designed by Tom Griffin	
DIMENSIONS ARE IN INCHES TOLERANCES: FRACTIONAL $\pm 1/64$ ANGULAR: MACH $\pm 1/2$ Deg. TWO PLACE DECIMAL $\pm .010$ THREE PLACE DECIMAL $\pm .005$		DRAWN	TG	12/20/11	TITLE: SPINDLE, MICROMETER CARRIAGE STOP
		CHECKED	TG	12/20/11	
DO NOT SCALE DRAWING				SIZE	DWG. NO.
MATERIAL				A	
FINISH				REV	A
		Quan	1 EA	SCALE: 2:1	WEIGHT:
				SHEET 1 OF 1	

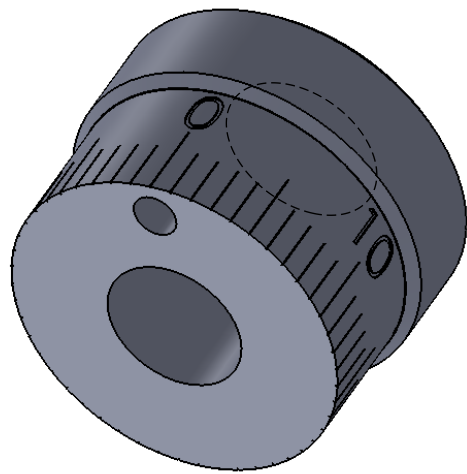
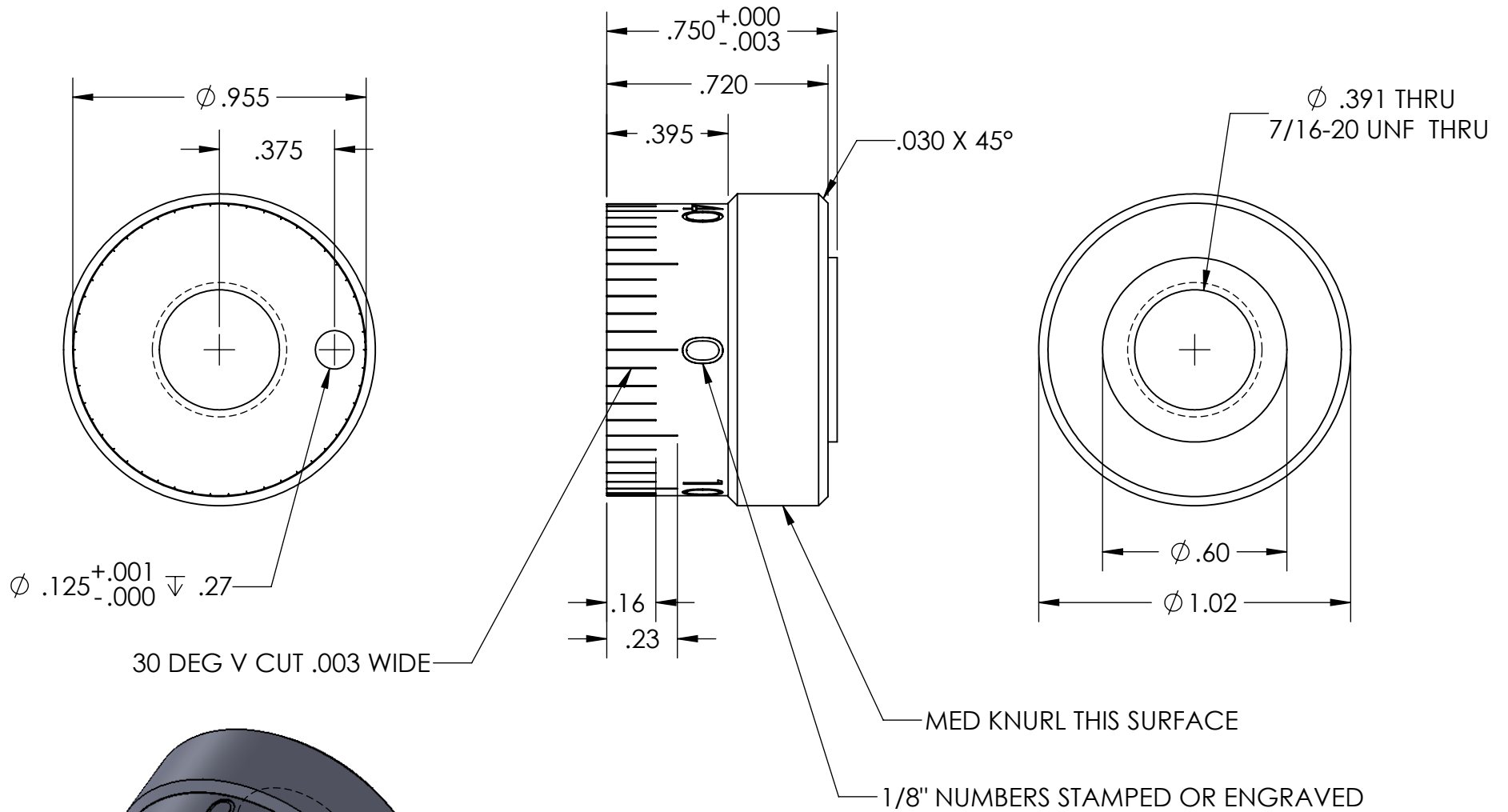

UNLESS OTHERWISE SPECIFIED:		NAME	DATE	Designed by Tom Griffin	
DIMENSIONS ARE IN INCHES TOLERANCES: FRACTIONAL $\pm 1/64$ ANGULAR: MACH $\pm 1/2$ Deg. TWO PLACE DECIMAL $\pm .010$ THREE PLACE DECIMAL $\pm .005$		DRAWN	TG	12/15/11	TITLE: THIMBLE, CARRIAGE STOP
		CHECKED	TG	12/15/11	
DO NOT SCALE DRAWING				SIZE	DWG. NO.
MATERIAL 303 STAINLESS STEEL				A	
FINISH		Quan	1 EA	SCALE: 2:1	WEIGHT: 0.13
				SHEET 1 OF 1	

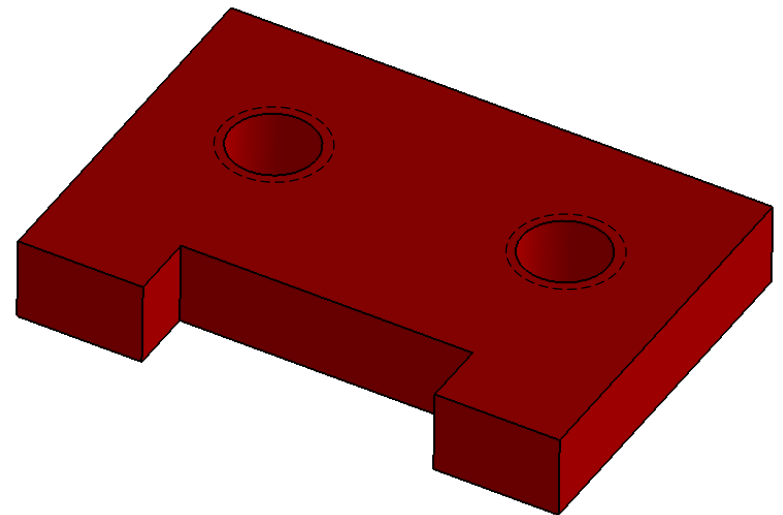
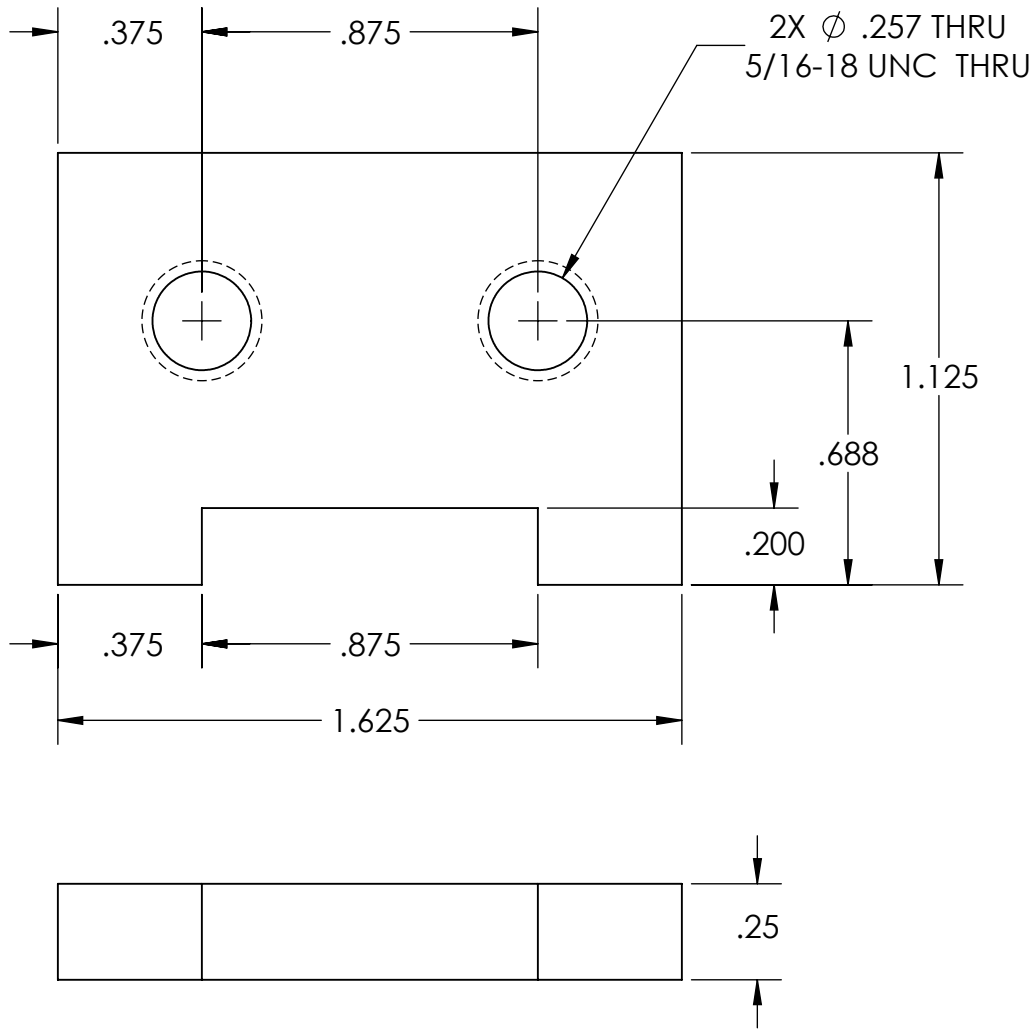

UNLESS OTHERWISE SPECIFIED: DIMENSIONS ARE IN INCHES TOLERANCES: FRACTIONAL $\pm 1/64$ ANGULAR: MACH $\pm 1/2$ Deg. TWO PLACE DECIMAL $\pm .010$ THREE PLACE DECIMAL $\pm .005$ DO NOT SCALE DRAWING MATERIAL Plain Carbon Steel FINISH	DRAWN	NAME	DATE	Designed by Tom Griffin TITLE: CLAMP, MICROMETER CARRIAGE STOP	
	CHECKED	TG	12/24/11		
	Quant	1 EA	SCALE: 2:1	WEIGHT: 0.11	SHEET 1 OF 1
	SIZE	DWG. NO.	REV		
A		A			